

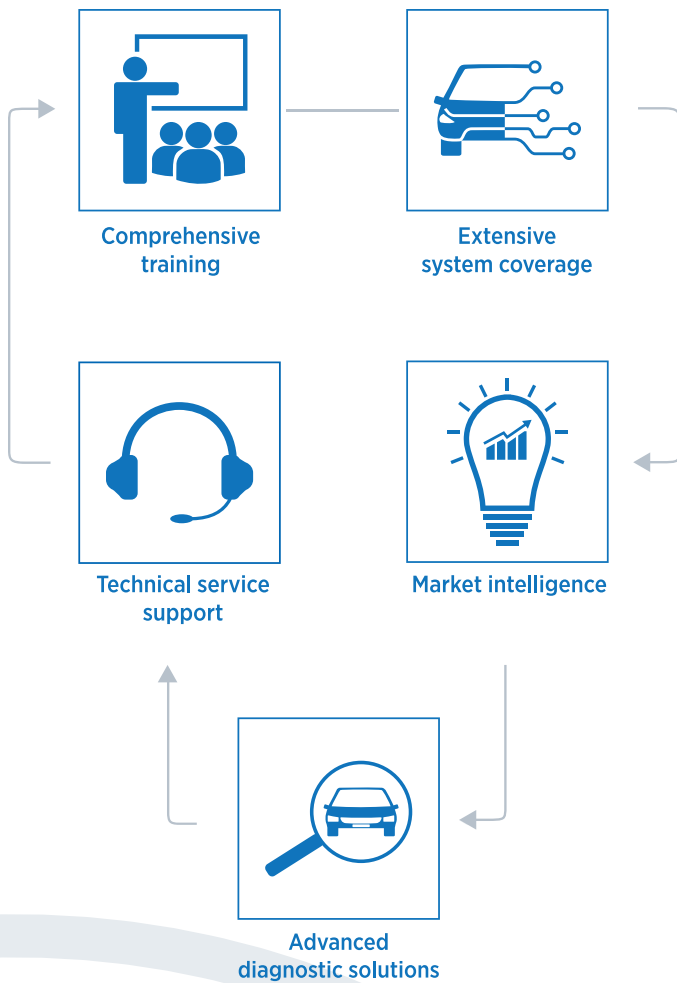

Hartridge CRi-Pro





Expert diagnostic solution for the latest generation of common rail injectors

The Hartridge CRi-Pro is an advanced and powerful 4-line common rail diesel test bench. This flexible and versatile machine is designed to accommodate the modern demands of diesel workshops around the world.

Features

- ✓ Tests up to 2700 bar
- ✓ Powerful 11kw motor
- ✓ Easy user experience designed throughout
 - » Closed-Loop technology
 - » Advanced, diagnostic steps
 - » Vast All-Makes testing & coding application coverage
- ◆ Enhanced Euro 6 response time measurement
- ◆ Advanced temperature control
- ◆ Reduced cycle time on C2i, C3i, C4i injectors*

Key:

- ✓ Standard machine feature
- » All-Makes feature
- ◆ Authorised feature

*Typically 20-30% reduction in cycle time versus the CRi-PC on C2i, C3i, and C4i injectors

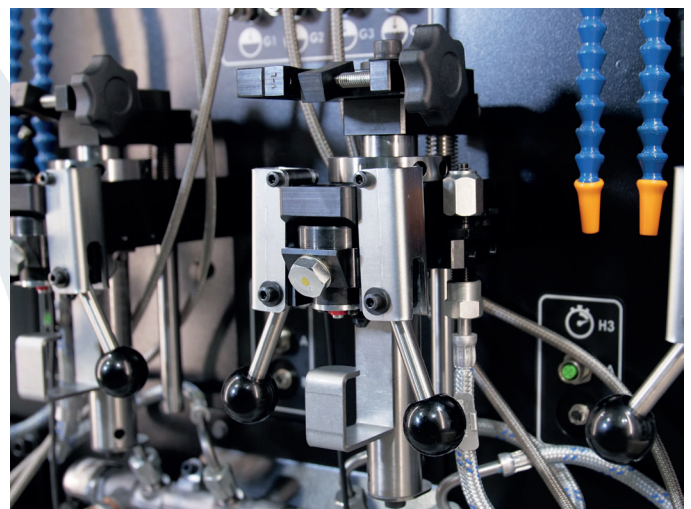

CRi-Pro specification overview for the aftermarket of today & tomorrow

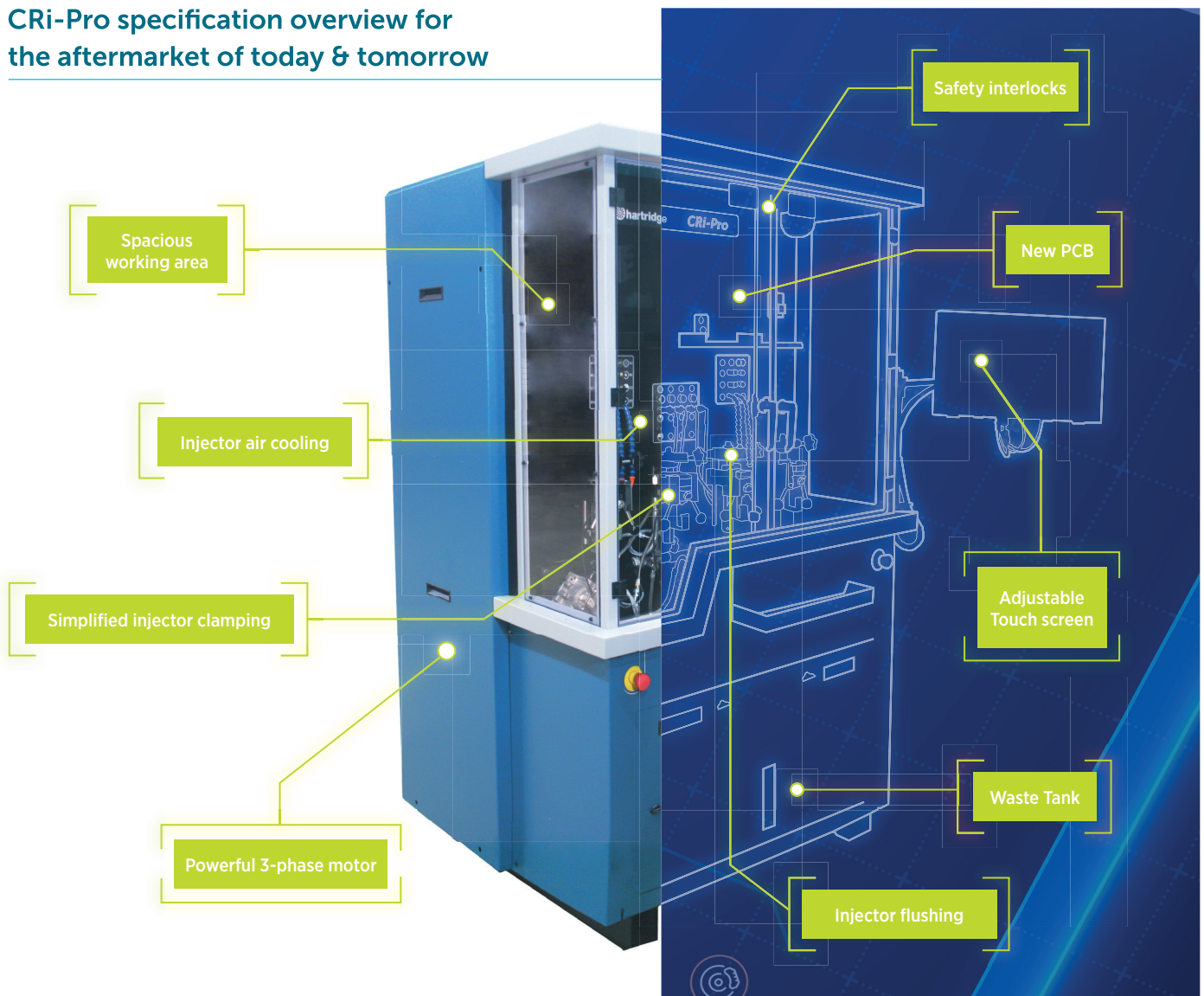

Easily interchange between two powerful software platforms

The CRi-Pro is authorised by Delphi Technologies to support the official repair programs for F2R, F2P, F2E and C2i, C3i, and C4i injector technologies via Delphi IRIS. This software is managed by an annual licence for ongoing authorisation.

The CRi-Pro also provides full All-Makes capability with the familiar Hartridge *magma^{Touch}* software giving access over a thousand of Bosch, Denso, and VDO coded test plans. *magma^{Touch}* is free of charge and managed with flexible pay-as-you-go licence credits purchasable on Hartridge. shop 24hrs a day.



Delphi Technologies **IRIS**



Ready for the aftermarket simplified application tooling

Whether in All-Makes or Authorised modes the fixturing has been designed specifically for flexibility

Simplified clamp load for authorised testing



D=200, D₁=210 mm, 700mm, D=250mm, D₁=260mm, D₂=300mm, D₃=350mm, 60 µm, 042 µf, 10-3000 imp.

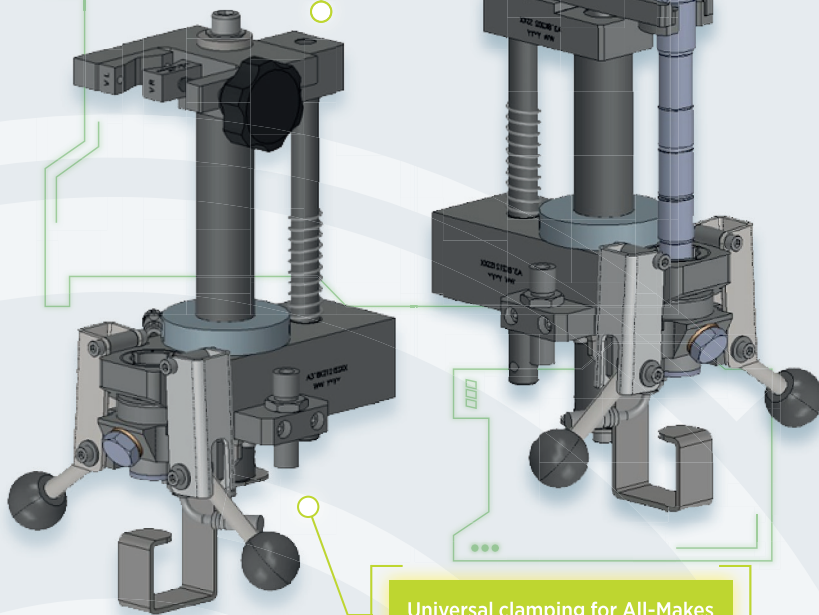

Universal clamping for All-Makes

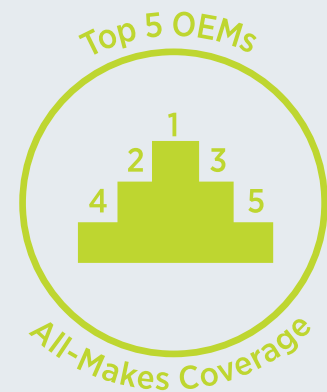
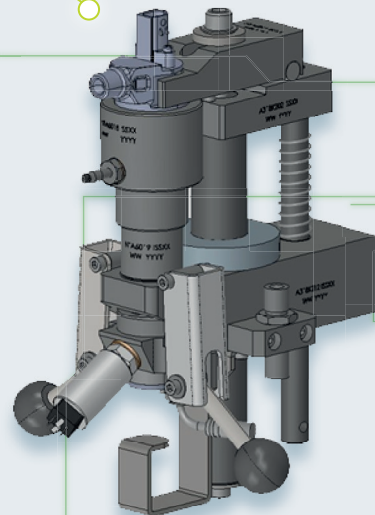

Superior flow and pressure power where it matters most

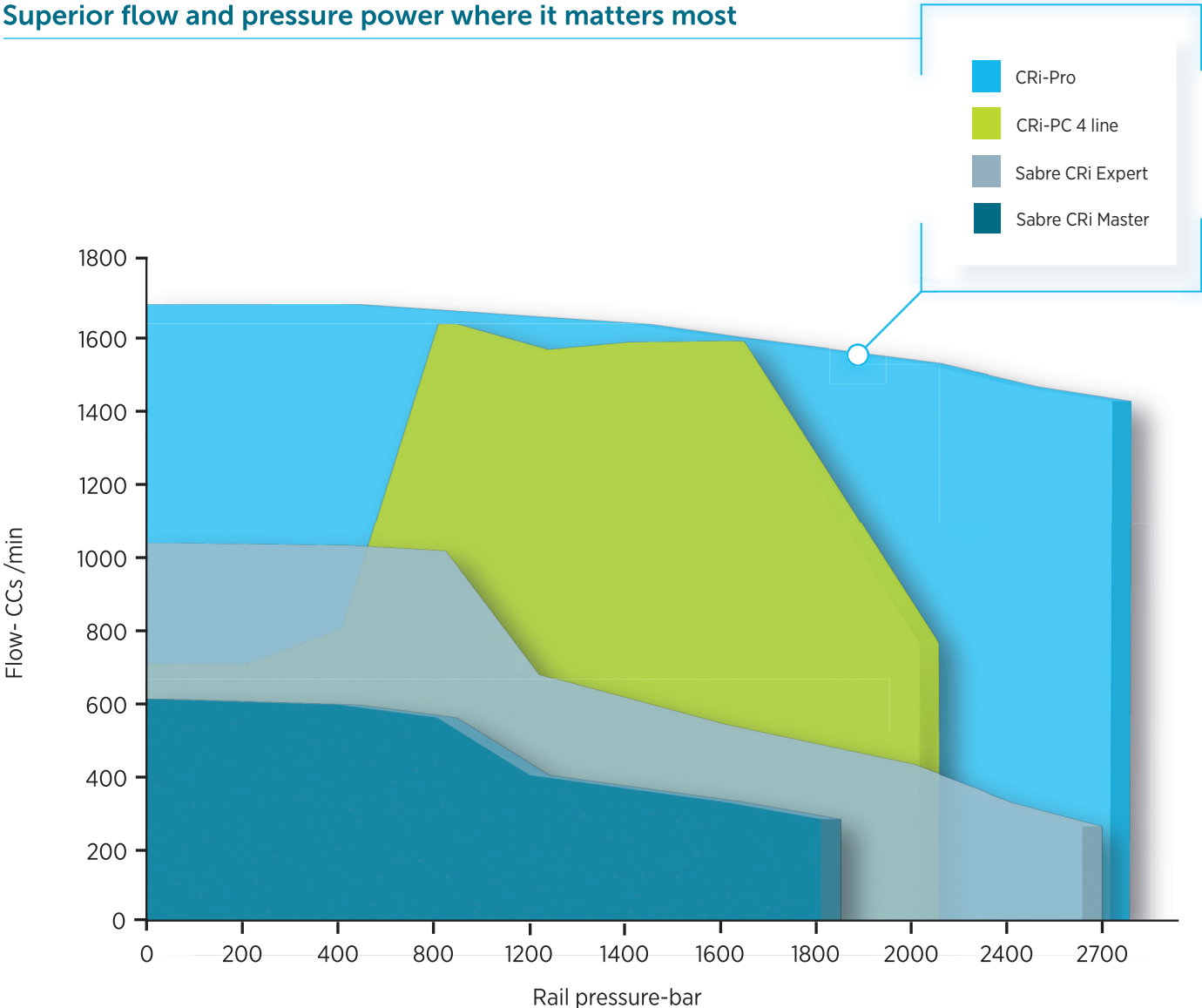

The CRi-Pro hydraulic operating envelope shows the CRi-Pro delivering optimum hydraulic performance at all levels of flow and rail pressure to cater to even the most demanding injectors.



Closed loop technology, expert diagnostic features such as 1PPR, MDP, NOP, and coding test plans.



Over 90 years heritage, OE engineering standards throughout, Delphi Technologies authorisation.



The CRi-Pro gives multi-sector coverage from one bench including passenger car, LCV, HDV, and off-highway.



Explore the CRi-Pro innovation and engineering excellence

The CRi-Pro has been designed from the ground up with user-friendly operation at the core of the test bench's functionality, from injector installation to final test result report. All machines are delivered fully calibrated and loaded with popular test plans.



Authorised Mode

Designed with a simplified method for achieving the clamp load required by OE authorised test plans without the reliance of part number specific clamp blocks.

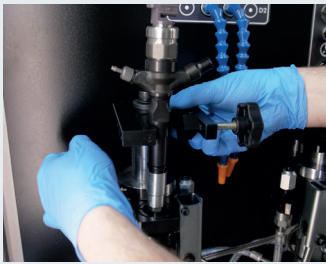
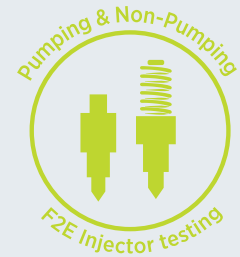

All-Makes Mode

The injector tooling method utilises existing All-Makes injector tooling for a vast reduction in accessories.

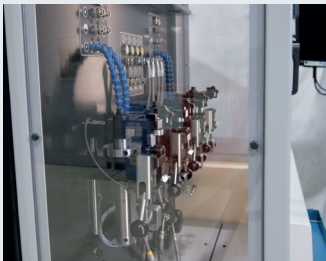

Volume Testing

Reduced cycle time for testing 4 injectors at the same time, compared to testing the same C2i, C3i, and C4i injectors on the CRi-PC.

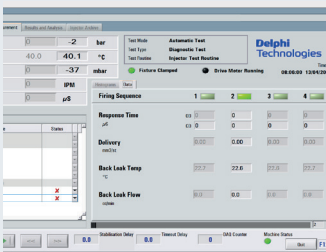

IRIS Software

Easily change between the all-makes and authorised modes to access the Delphi Technologies IRIS software for Authorised workshops.

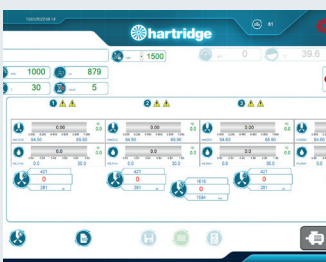

Magmah^{Touch} Software

The dynamic display shows the technician one test step at a time and the real-time pass or fail progress of the test.



Ready for the workshop built to enhance productivity

Quick injector installation

Open working area

Space for tools in easy reach



Intuitive touch screen interface

Set-and-forget test plan mode to save time

Pioneering product portfolio: Find the right Common Rail solution for you

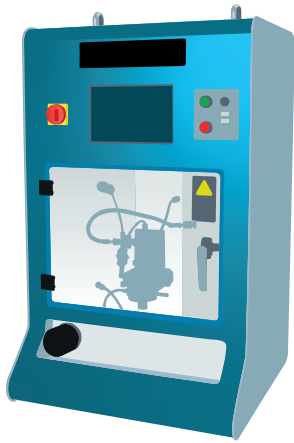

The Hartridge portfolio has a range of solutions to serve diesel and gasoline technologies, and the CRi-Pro can connect with the Delphi Technologies authorised injector repair program for a holistic Euro 6 solution.

The Sabre CRi-Expert

- ✓ All-Makes only
- ✓ Simple installation
- ✓ Single injector testing

The CRi-Pro

- ✓ All-Makes & authorisation
- ✓ Air cooling as standard
- ✓ Up to 4 injectors at a time

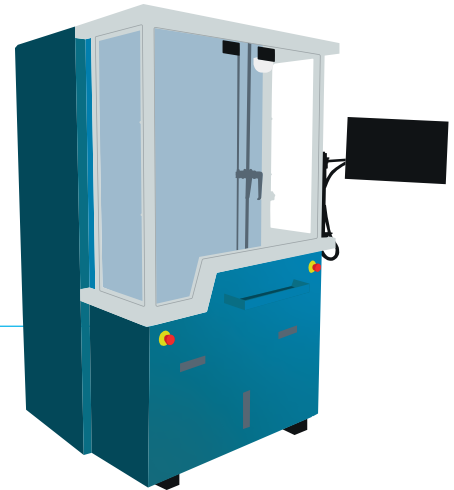

The AVM2-PC

- ✓ Industry favourite
- ✓ Extra equipment required
- ✓ Injector and pump testing



Contact your local **Hartridge™** distributor for more detailed information or visit hartridge.com



Hartridge. The Hartridge Building. Network 421, Radclive Road, Buckingham MK18 4FD. United Kingdom
Tel: +44 (0)1280 825600 Fax: +44 (0)1280 825601 Email: sales@hartridge.com www.hartridge.com

Continuous development is taking place. Hartridge reserves the right to alter the design and/or specification without prior notice.

© Hartridge 2023 / CRi-Pro EN 11/23 v1.0